

PRO-12D4

Congratulations on your choosing a SUONO subwoofer. For best results, we recommend using one of the acoustic enclosures described below. You can build your enclosure exactly as described or simply use the net volumes and ports specified. Please note the volumes specified are Net Internal Volumes. You must add woofer displacement, port displacement and brace displacements to obtain the Gross Internal Volume. The enclosure dimensions shown are already taking all of this into account. The Sealed Box is the smallest and more natural box, but not as loud. The Ported Box is more dynamic but bigger. The Band-Pass box represents an excellent option for those looking for a more intense bass response.

Characteristics

12" subwoofer, dual 4 ohms voice coils, die-cast aluminum basket, Kevlar fiber-reinforced non-pressed pulp cone, sewn-in extended range of motion foam cone suspension, exposed 2.5" four-ply copper high-temperature voice coil with aluminum former, dual poly-cotton spider, double magnet 60 ounces each. Specifications subject to change without notice.

Building an Acoustic Enclosure

As construction material, we suggest MDF or high-density chipboard at least 3/4 inches thick. Cuts should be made with a table-mounted circular saw or better. It is also convenient to include internal reinforcements to give the box greater solidity. Acoustic enclosures should also always include some fiberglass or dacron inside as an acoustic absorber, taking care that it does not come into contact with the loudspeaker or port. All enclosures should be securely bolted to the car so they don't become a projectile during a collision.

Voice Coil connection

Even though this woofer has two 4-ohm terminals, both terminals form a single winding. Therefore, both coils should ALWAYS be connected. If they are connected in series the impedance goes up to 8 ohms (1), and if they are connected in parallel it goes down to 2 ohms (2). For two subwoofers it is possible to make a series-parallel configuration to get a final impedance of 4 ohms (3), or you can connect all coils in parallel to go down to 1 ohm (4). **Note:** In any parallel connection the length of each wire for each coil must be exactly the same.

(1)

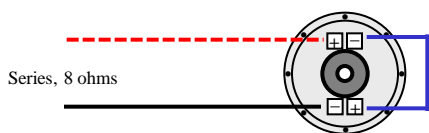

(3)

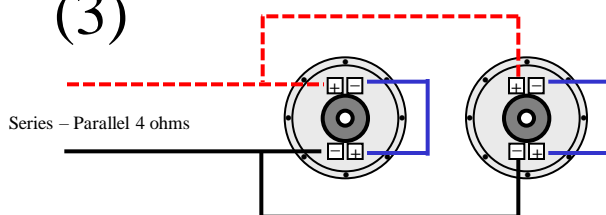

(2)

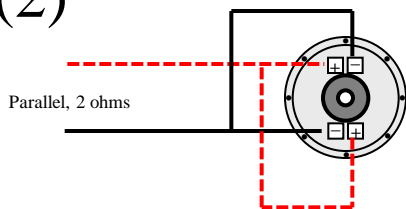

(4)

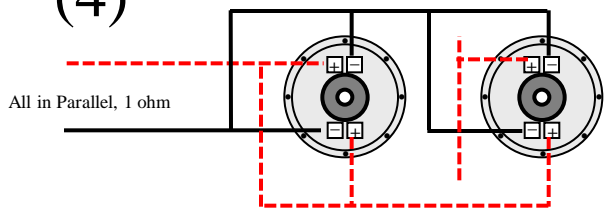

Thiele-Small Parameters		Dimensions	
Fs:	35 Hertz	A	12.8" / 325 mm
Qes:	0.63	B	6.7" / 17 mm
Qms:	6.86	C	0.63" / 16 mm
Qts:	0.577	D	6.62" / 168 mm
Vas:	1.4 ft ³	E	6.38" / 162 mm
Z nom:	4 + 4 ohms	F	11.34" / 288 mm
X max:	13 mm		
BL:	22 Tm		
P:	600 Watts RMS		
Re:	6.8 ohms		
Sensitivity	86 dB SPL @ 1W/1m		
Displacement	0.15 ft ³		

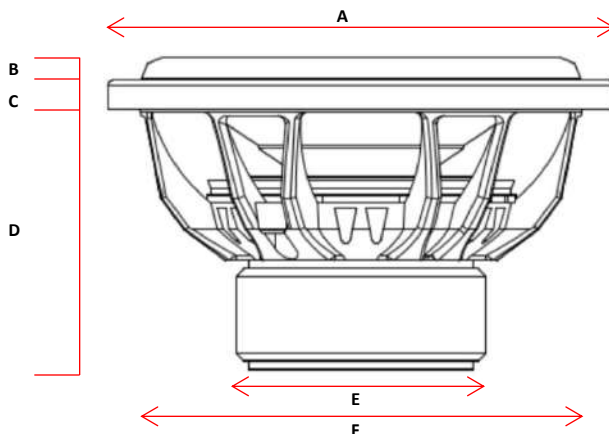

RECOMMENDED SPEAKER BOXES. In the designs below, the thickness of the wood is 3/4". Always use the wood in the designs below. The thickness of the wood is 3/4". Add some fiberglass or dacron inside. The reinforcement can be the dividing wood of the double boxes or the one indicated in the individual ones.

Single Woofer, Sealed Box. Net Internal Volume: 1 ft³
 F3 = 45 Hertz, Qtc = 0.89

To cut: 2 pieces 22" x 14"
 2 pieces 22" x 7.75"
 2 pieces 12.5" x 7.75"
 1 piece 4" x 7.75" as reinforcement

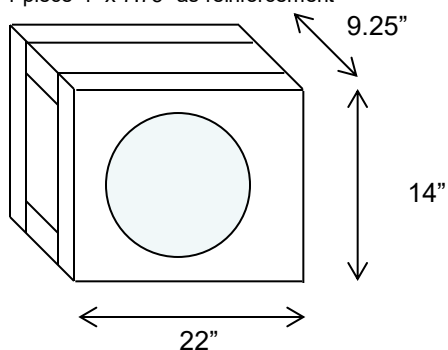

Two Woofers, Sealed Box. Net Internal Volume per side: 1 ft³

To cut: 2 pieces 35" x 14"
 2 pieces 35" x 9.7"
 3 pieces 12.5" x 9.7" (one is the division)

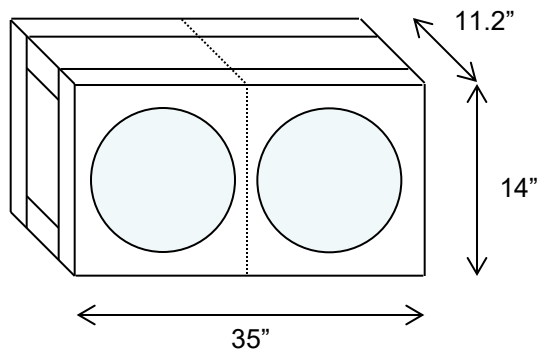

Single Woofer, Ported Box. Net Int. Volume: 1.8 ft³, F3: 30 Hz, Fb 35 Hz

To cut: 2 pieces 28" x 14"
 2 pieces 28" x 10.6"
 2 pieces 12.5" x 10.6"
 1 piece 4" x 10.6" as reinforcement

Tuned with a single **4" diameter port, 12" long**

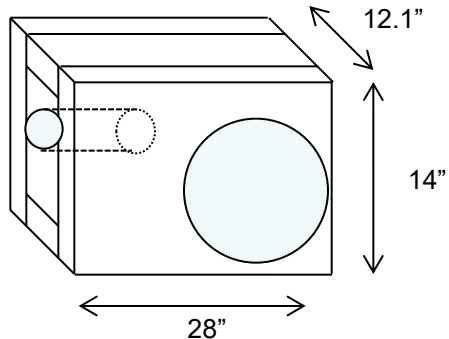

Two Woofers, Ported Box. Net Internal Volume per side: 1.8 ft³

To cut: 2 pieces 35" x 15"
 2 pieces 35" x 15.9"
 3 pieces 13.5" x 15.9" (one is the division)

Each woofer with its own **4" diameter port, 12" long**

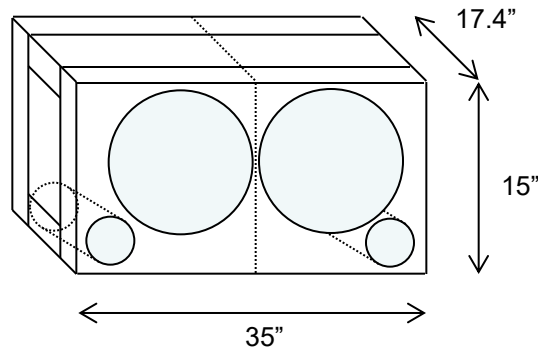

4th Order Band-Pass. Sealed Net Volume: 0.55 ft³, Ported Net Volume: 1 ft³, Fb: 66 Hz

To cut: 2 pieces 20.4" x 14.5"
 2 pieces 20.4" x 13"
 3 pieces 13" x 13" (one is where the woofer will be mounted)

Tuned with a single **6" diameter port, 5" long**

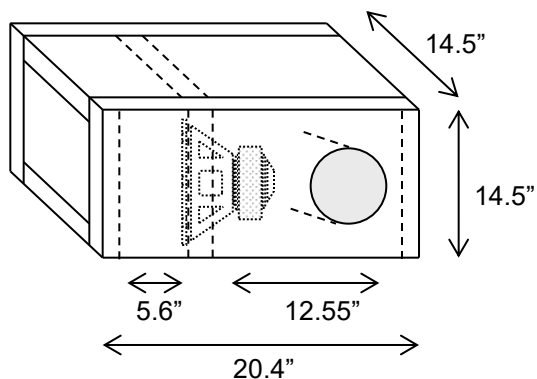

4th Order Band-Pass, Two Woofers

To cut: 2 pieces 35" x 15"
 2 pieces 35" x 14.3"
 4 pieces 13.5" x 14.3"

Tuned with a single **8" diameter port, 7" long**

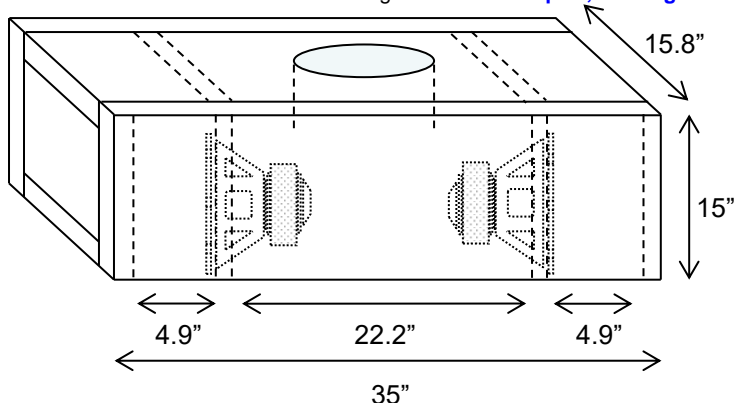

WARRANTY:

SUONO products are guaranteed for one year for the original retail purchaser against defects in material and workmanship. Products found to be defective will be repaired or replaced (at SUONO's discretion) at no charge. Damage caused by misuse, abuse, product modification, accidents, improper installation, water, and unauthorized repair attempts is not covered. Cosmetic or finish damages are not covered. Products not purchased in the United States from an authorized dealer are not covered. Incidental or subsequent damages to other products are not covered. Any costs or expenses for removing and/or reinstalling the product are not covered. SUONO's total liability will not exceed the purchase price of the product. Some states do not allow limitations on implied warranties so this may not apply to you. You are responsible for the shipment of your product to SUONO. Please get in touch with SUONO first to get a Return Authorization Number.

SUONO CAR AUDIO LLC

1517 Pech Road, Houston, Texas 77055. USA

Phone : (832) 853 71 85 juan.castillo@suonocaraudio.com www.suonocaraudio.com